

MORETTIDESIGN

MANUALE DEDICATO - DEDICATED MANUAL - MANUAL DEDICADO
MANUEL DÉDIÉE - DIENSTLEISTUNG-HANDBUCH - MANUAL DEDICADO
DEDIKERET MANUEL - GEWIJDDE HANDLEIDING - UŽÍVATEĽSKÁ PRÍRUČKA
UŽIVATEĽSKÁ PRÍRUČKA - DEDYKOWANA INSTRUKCJA - MANUAL DEDICAT

INTELLIGENT TANK



INDICE

INTELLIGENT TANK	3
INTELLIGENT TANK FOR ALL	11
NG21	21

IT - ISTRUZIONI PER L'ASSEMBLAGGIO DEI COMPONENTI

Seguire le seguenti istruzioni numerate per un corretto assemblaggio dell'INTELLIGENT TANK

EN - INSTRUCTIONS FOR ASSEMBLING THE COMPONENTS

Follow the numbered instructions for a proper assembly of the components of the INTELLIGENT TANK

ES - INSTRUCCIONES PARA EL MONTAJE DE LOS COMPONENTES

Siga las instrucciones numerados a continuación para el montaje correcto de los INTELLIGENT TANK.

FR - INSTRUCTIONS D'ASSEMBLAGE DES COMPOSANTS D'HABILLAGE

Suivez les instructions ci-dessous numérotées pour l'assemblage correct de L'INTELLIGENT TANK.

DE - HINWEISE ZUM ZUSAMMENBAU DER KOMPONENTEN

Folgen Sie den unten nummerierten Instruktionen für die richtige Montage des INTELLIGENT TANKS.

PT - INSTRUÇÕES PARA MONTAGEM DOS COMPONENTES

Siga as instruções abaixo enumeradas para a montagem correta dos INTELLIGENT TANK

DA - INSTRUKTIONER TIL MONTERING AF DE KOMPONENTER

Følg de nummererede instruktioner for korrekt monterning af komponenterne i INTELLIGENT TANK

NL - AANWIJZINGEN VOOR HET MONTEREN DE ONDERDELEN

Volg de genummerde instructies voor een juiste montage van de componenten van de INTELLIGENT TANK

SK - POKYNY PRE MONTÁŽ KOMPONENTOV

Riadte sa očíslovanými pokynmi pre správne zostavenie komponentov INTELLIGENT TANK

CS - POKYNY PRO MONTÁŽ KOMPONENTŮ

Postupujte podle číselovaných pokynů pro správnou montáž součástí INTELLIGENT TANK

PL - INSTRUKCJA MONTAŻU SKŁADU

Postępuj zgodnie z ponumerowanymi mocami w celu montażu elementów INTELLIGENT TANK

RO - INSTRUCȚIUNI PENTRU MONTAREA COMPONENTELOR

Urmați următoarele instrucțiuni numerotate pentru o asamblare corectă a INTELLIGENT TANK

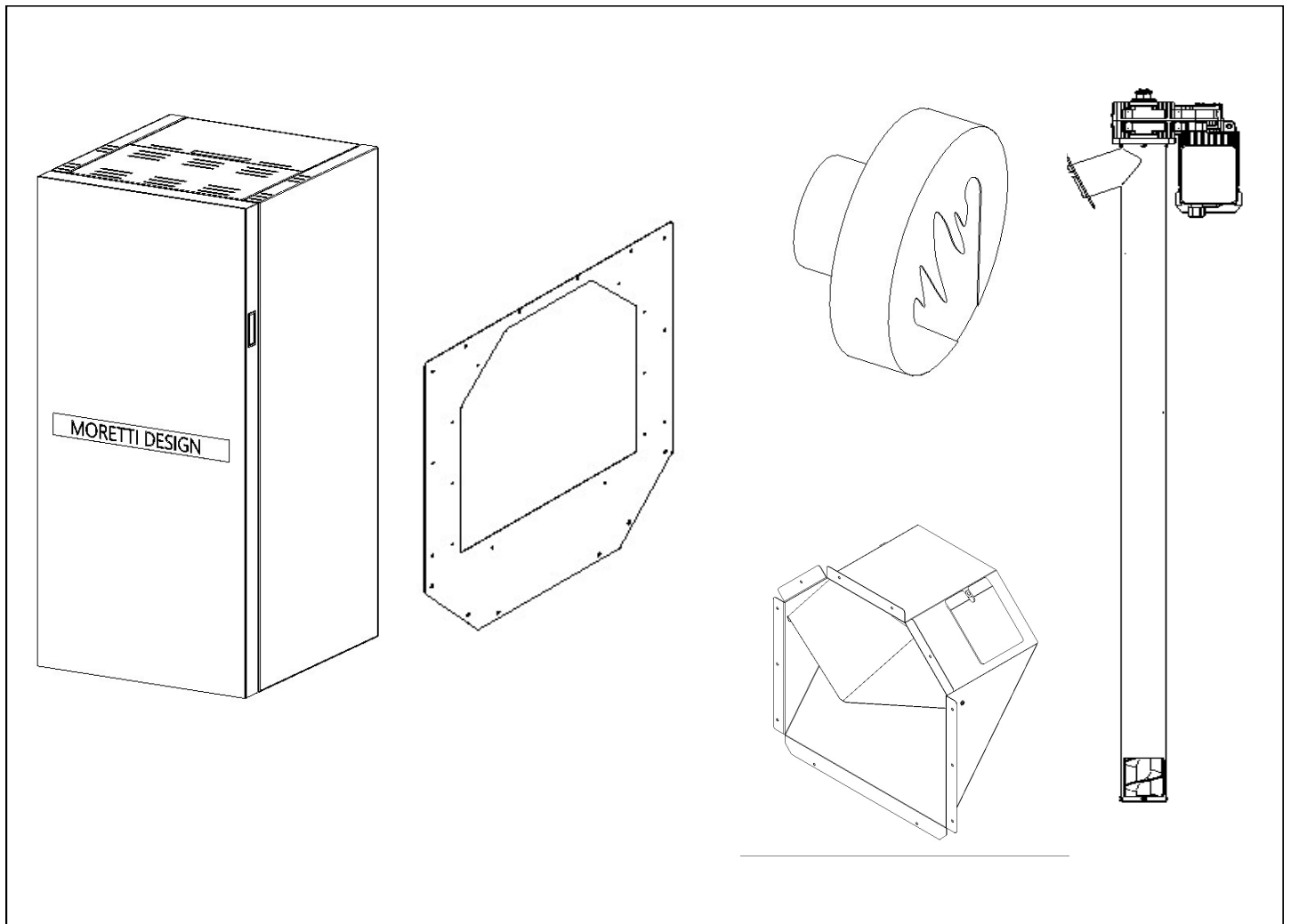

1

**TECNICA FOR HOME
TECNICA GLASS**

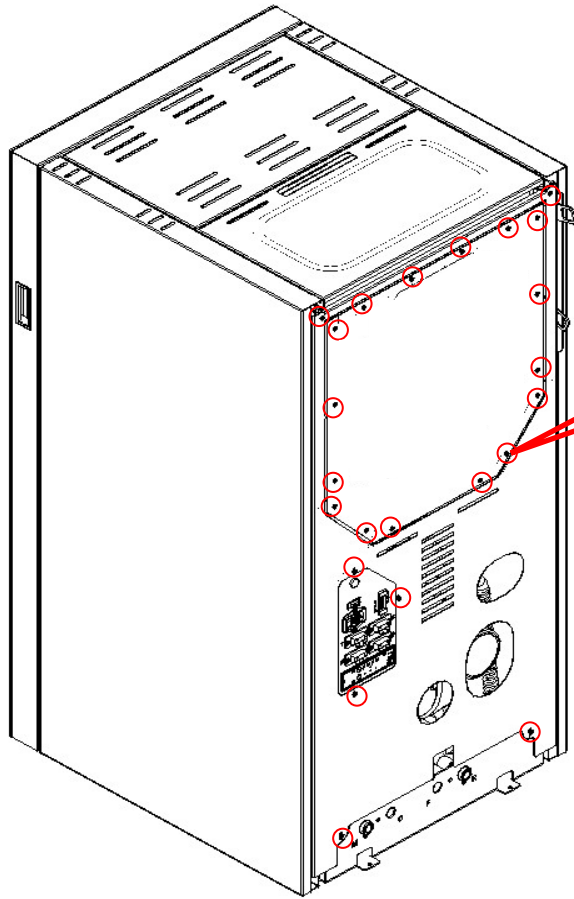

X23



2

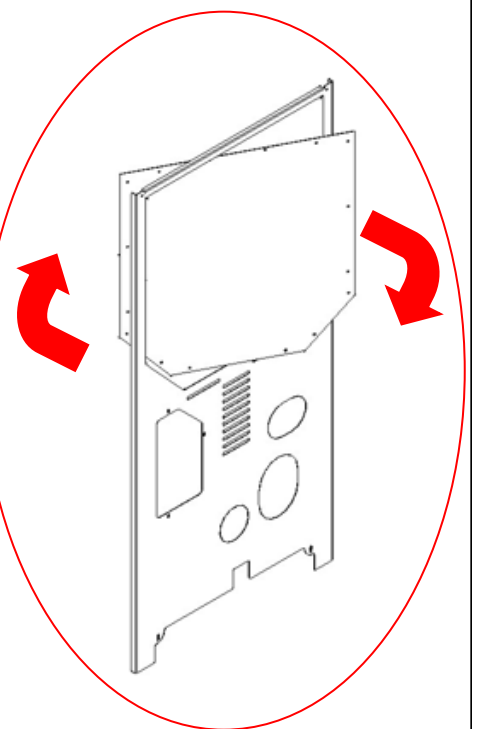
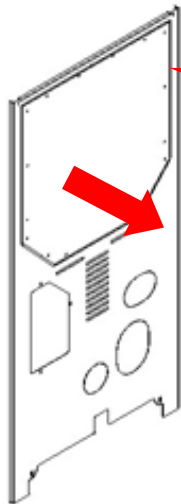
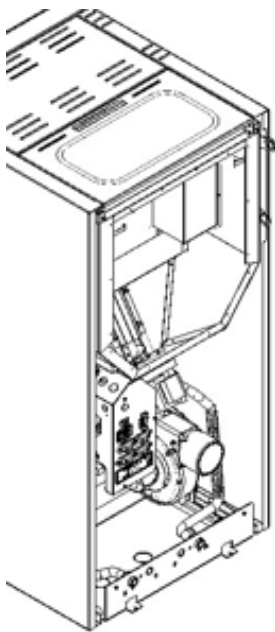

3

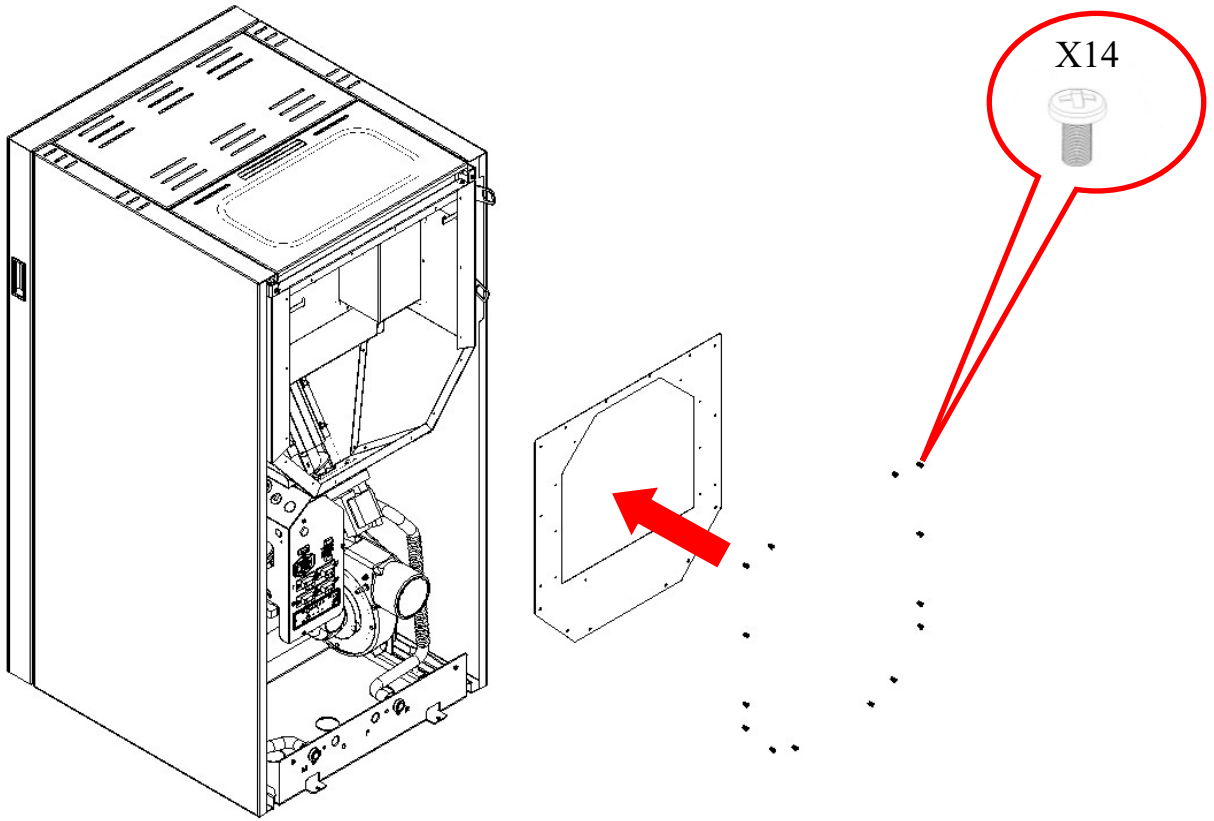

4

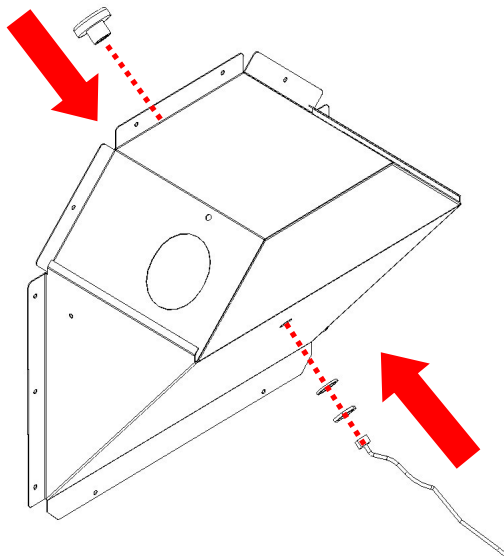

5

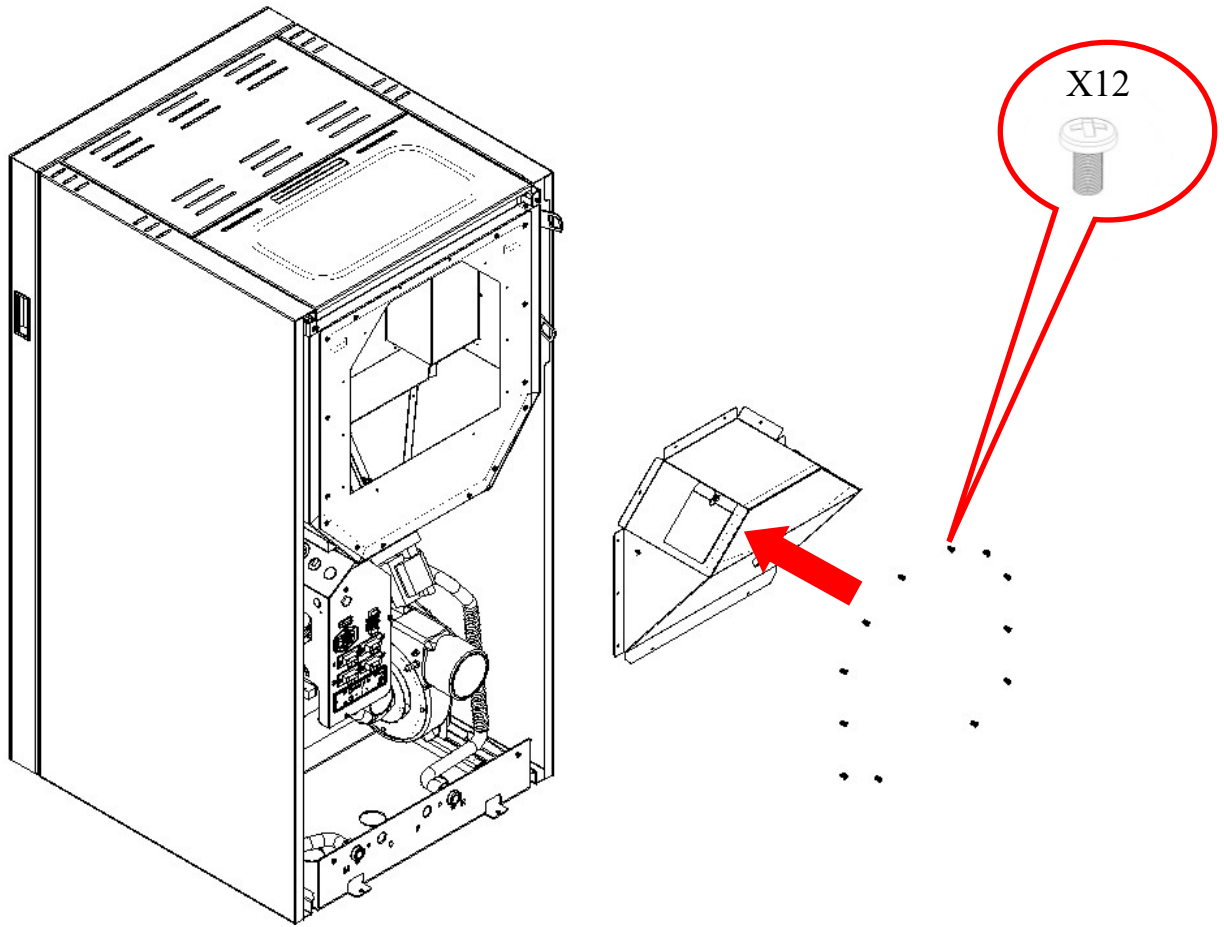

6

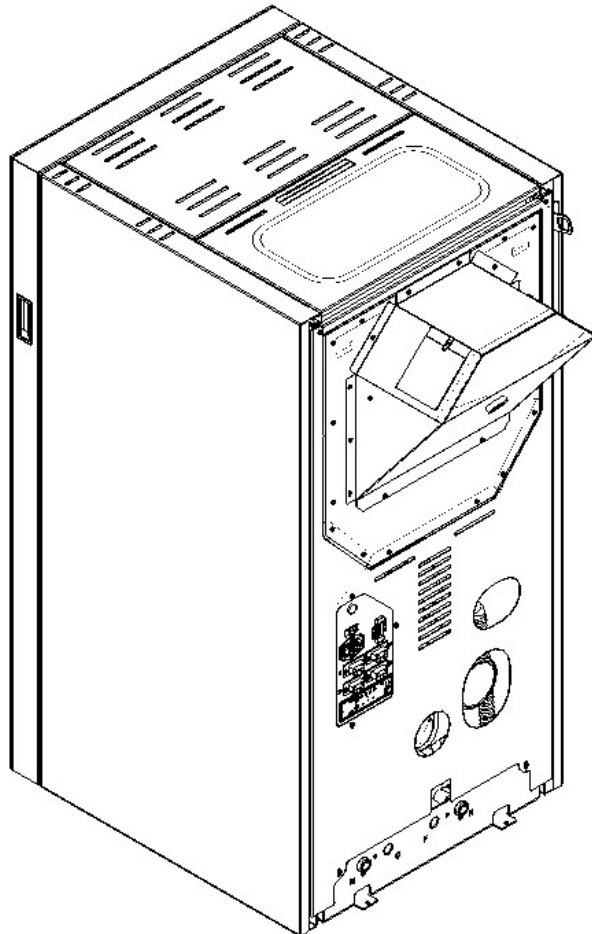

7



MOTOR SX

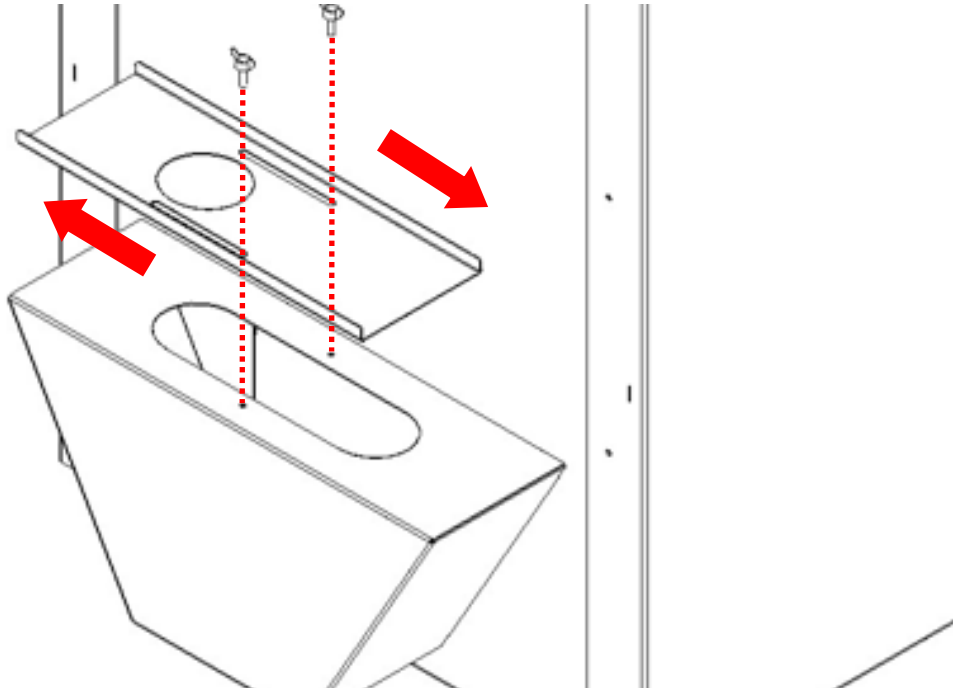

8

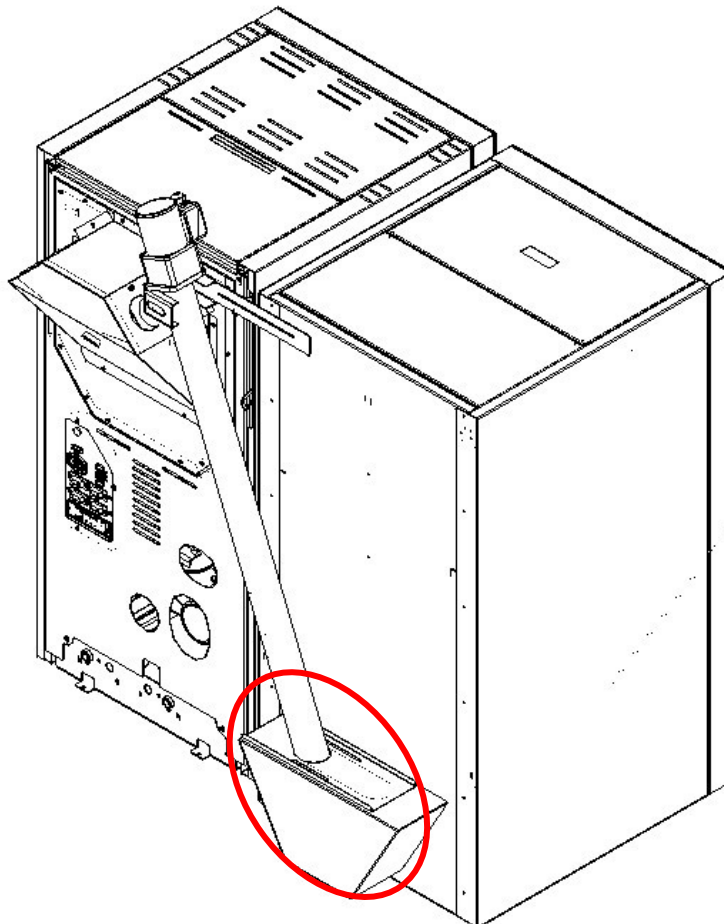

9

MOTOR DX

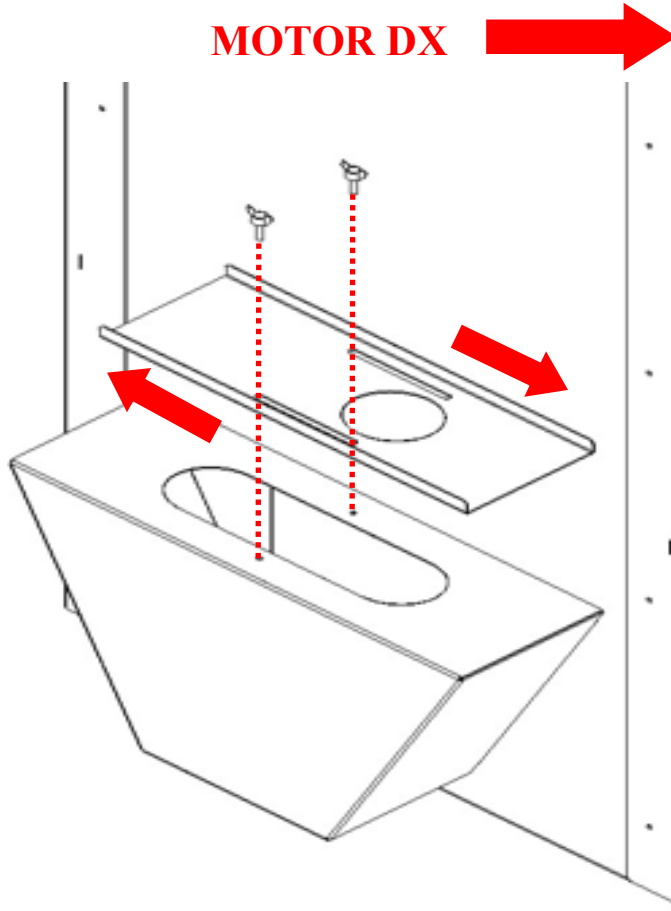

10

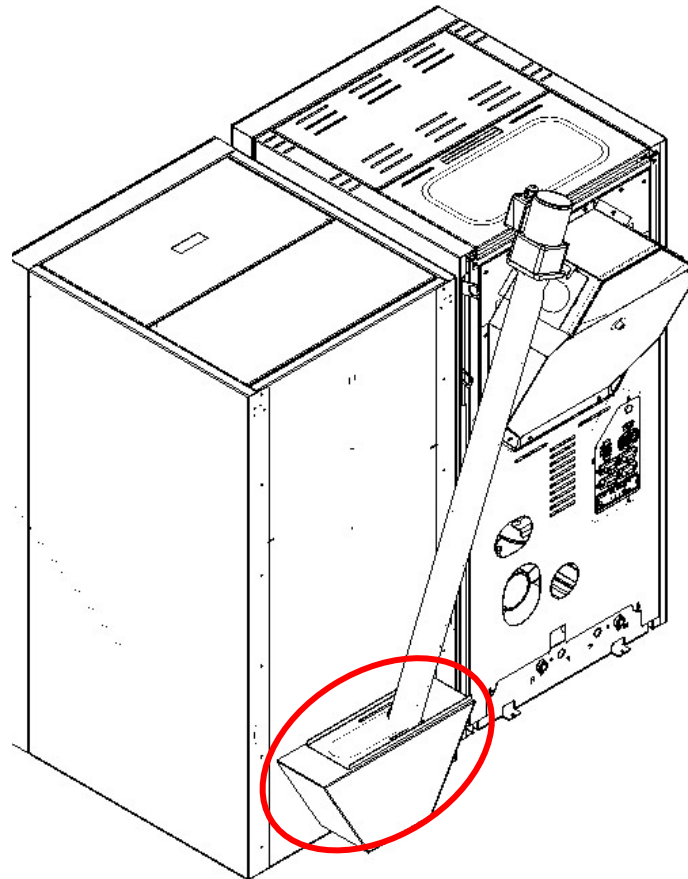

11

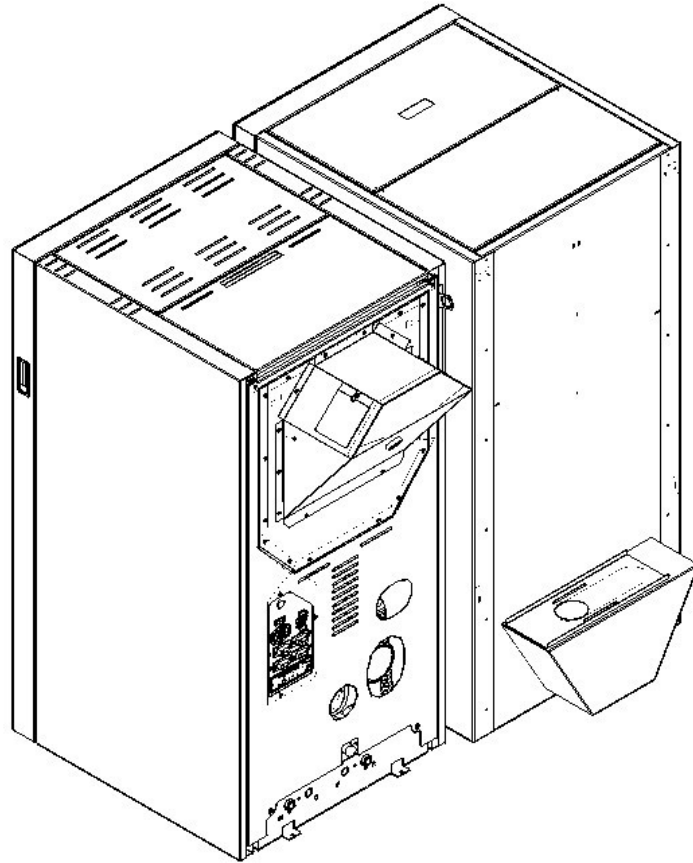

12

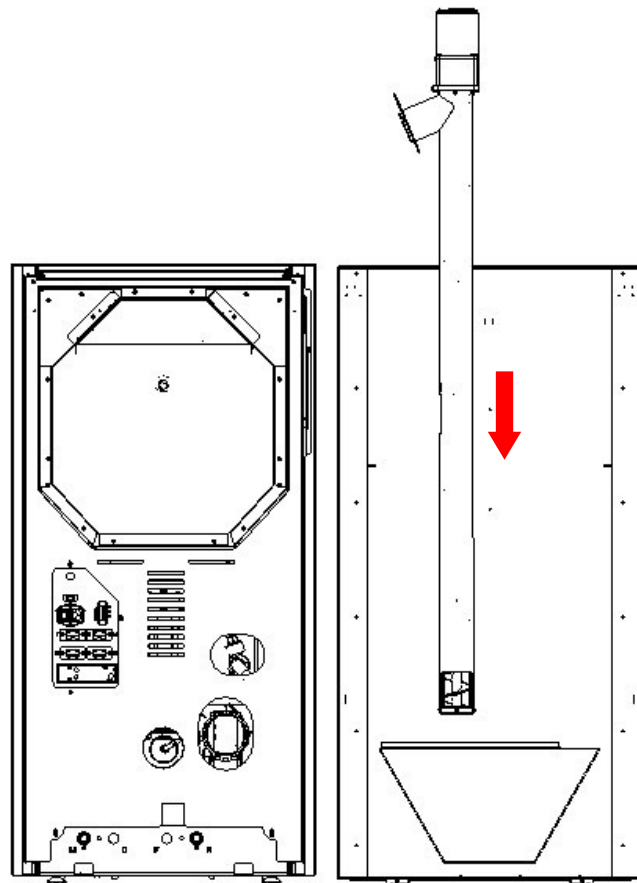

13

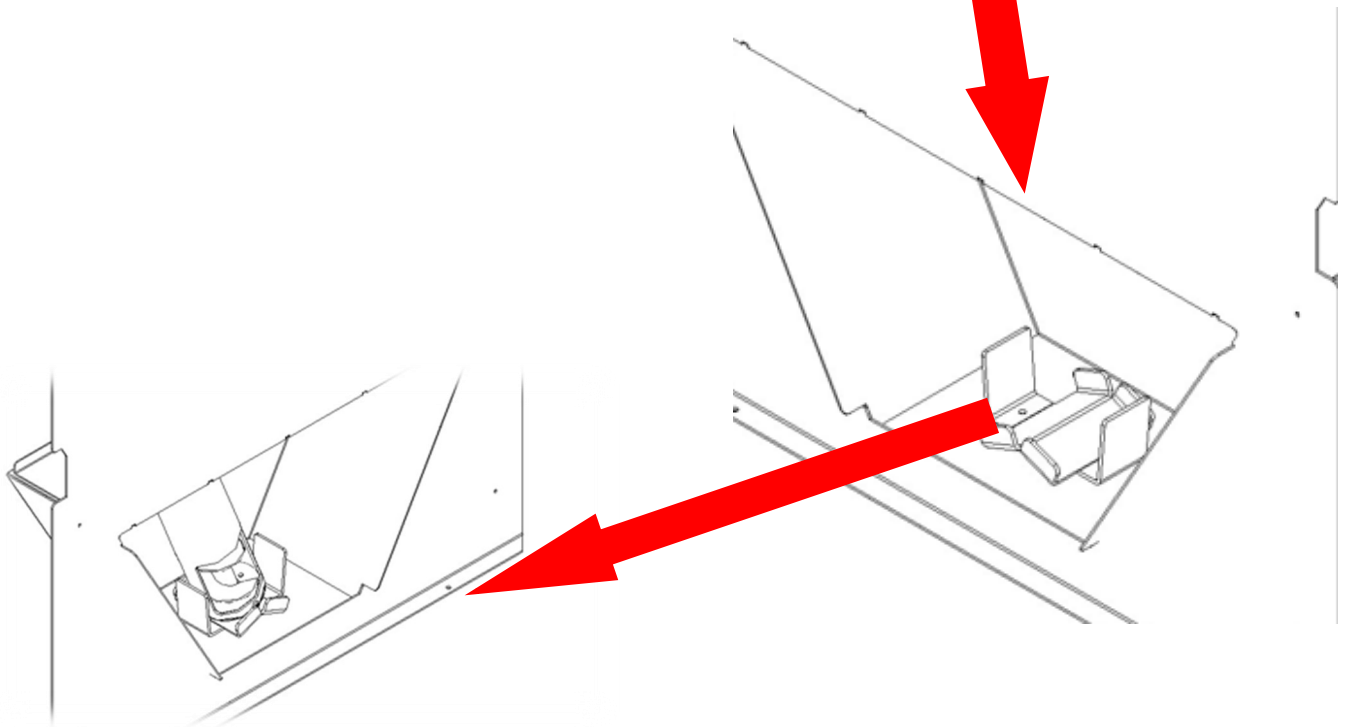
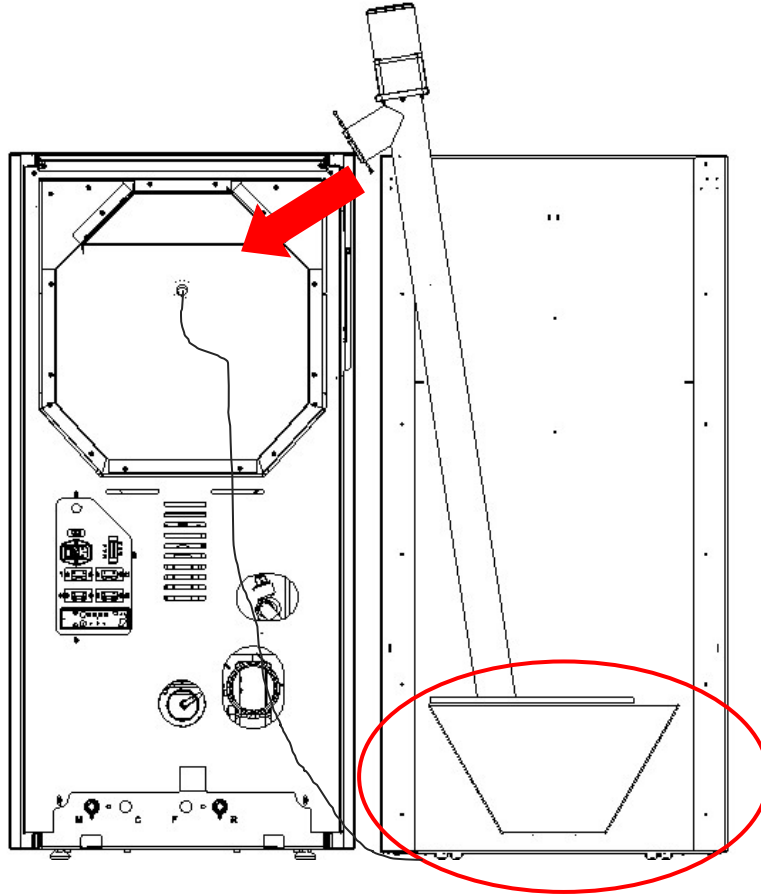

14

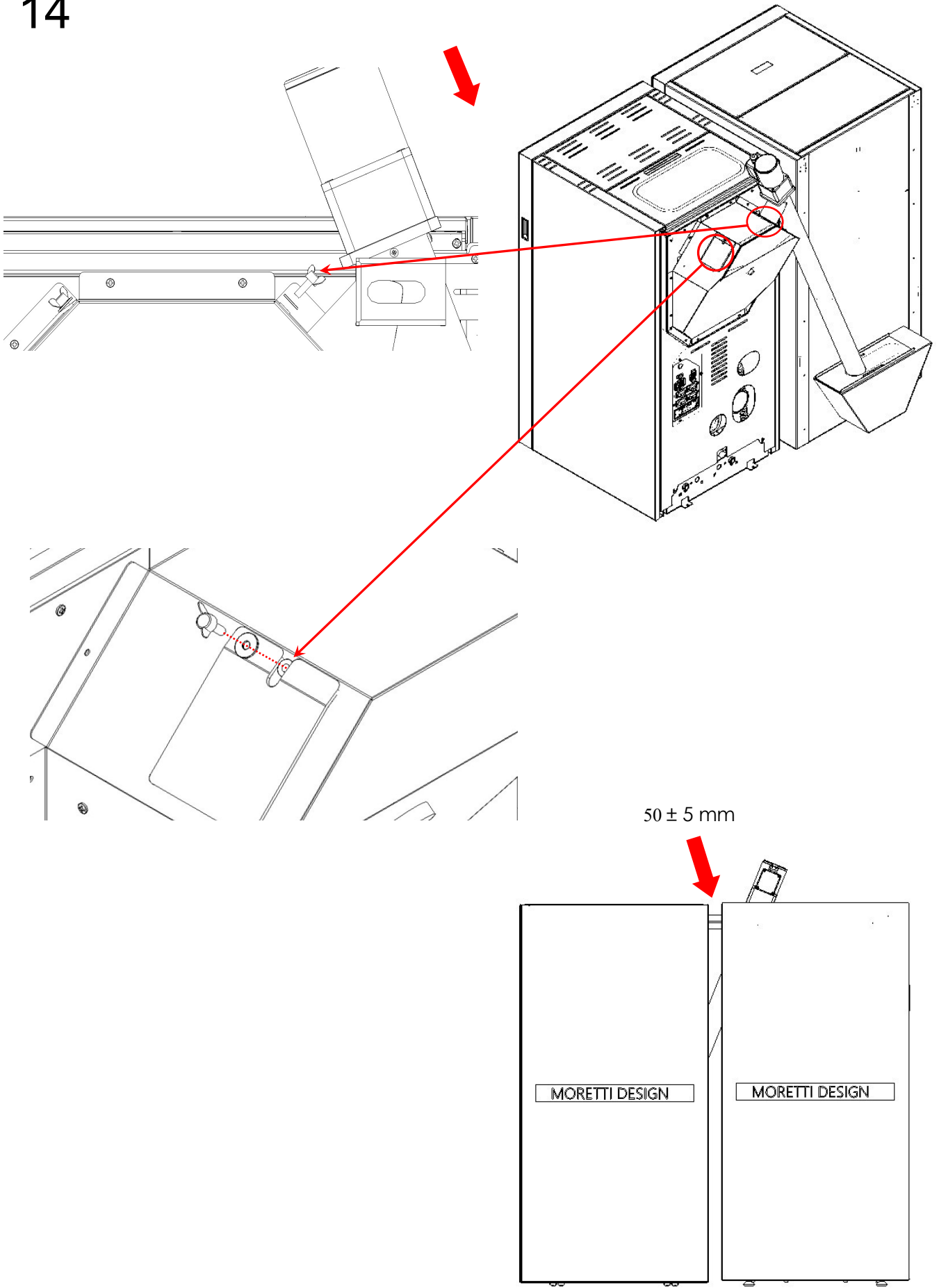

15

INTELLIGENT TANK FOR ALL

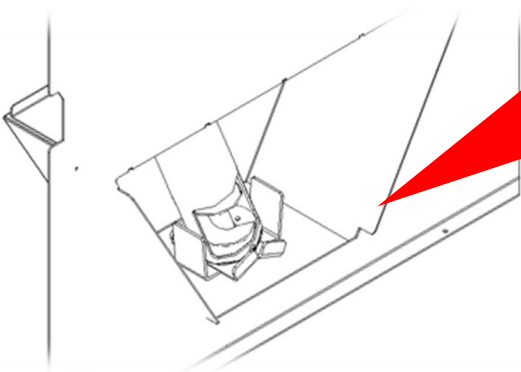
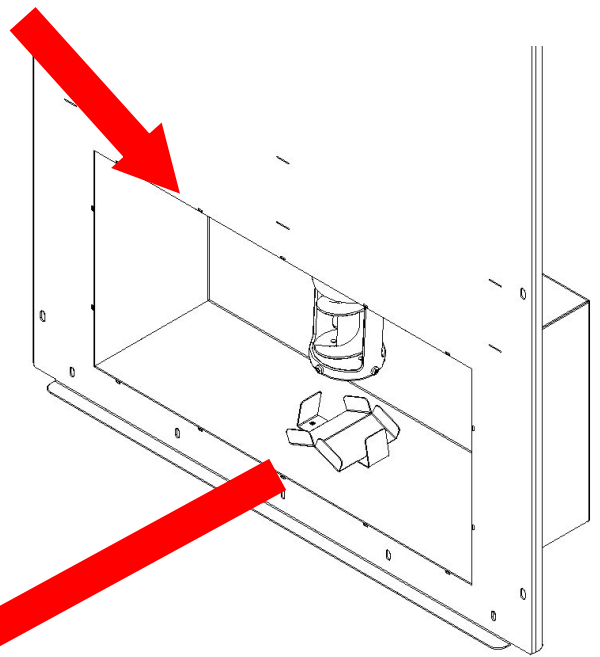
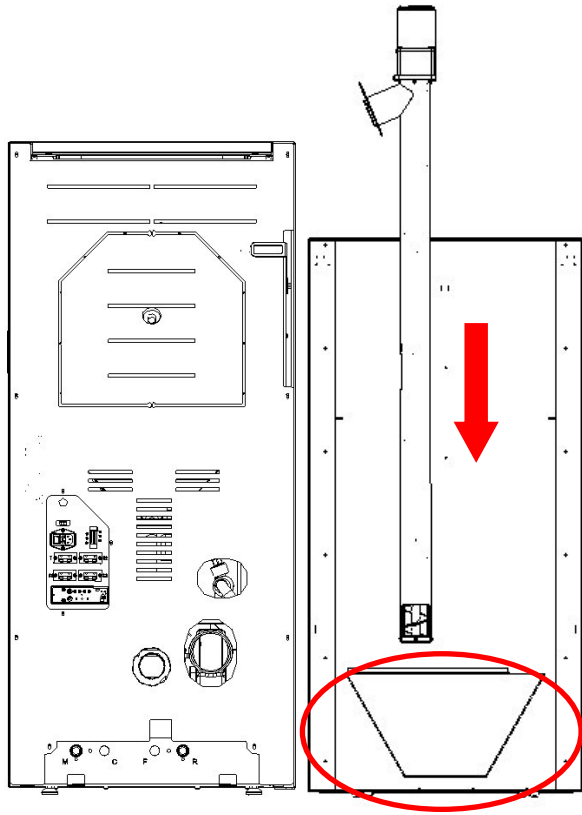

16

INTELLIGENT TANK FOR ALL

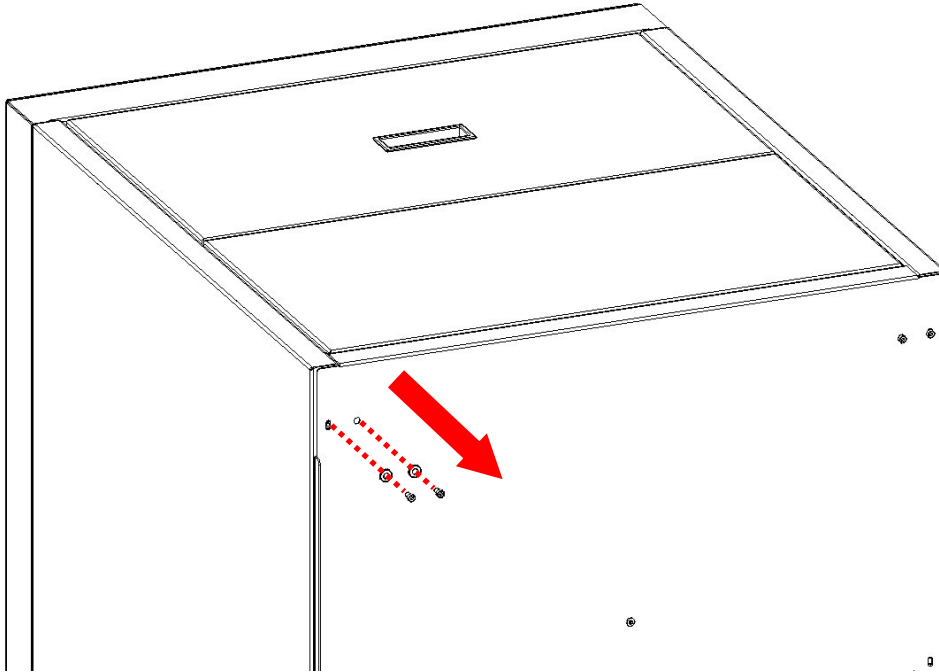

17

INTELLIGENT TANK FOR ALL

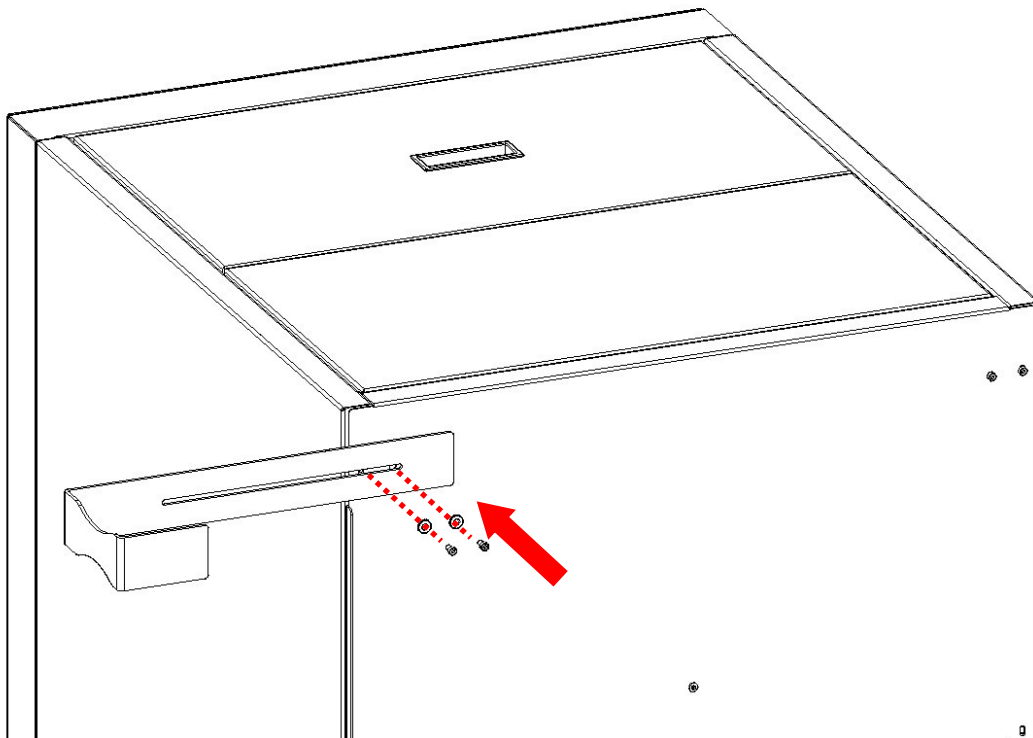

18

INTELLIGENT TANK FOR ALL

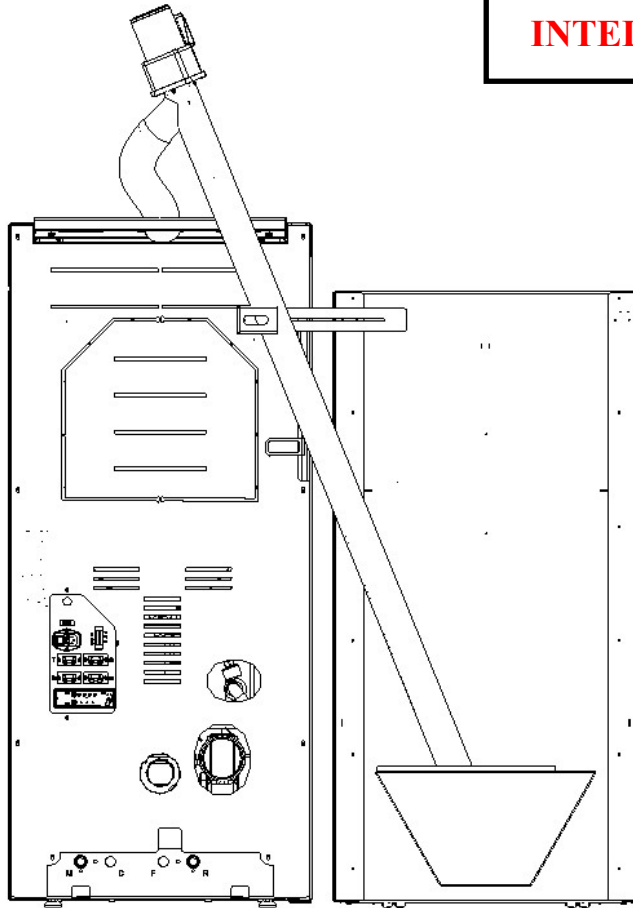

19

INTELLIGENT TANK FOR ALL

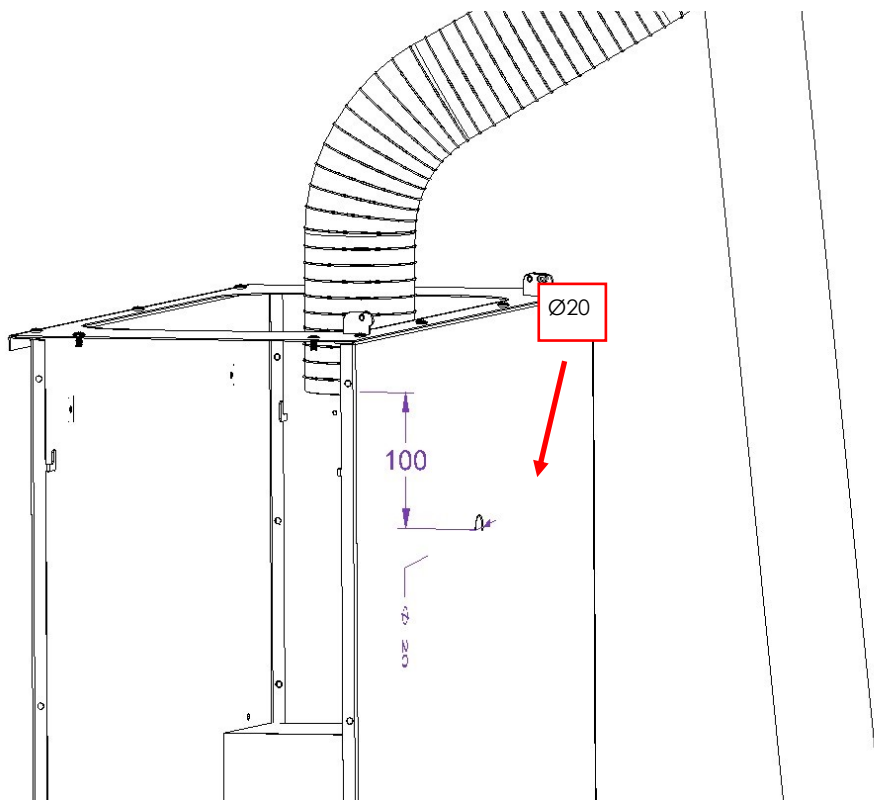

20

INTELLIGENT TANK FOR ALL

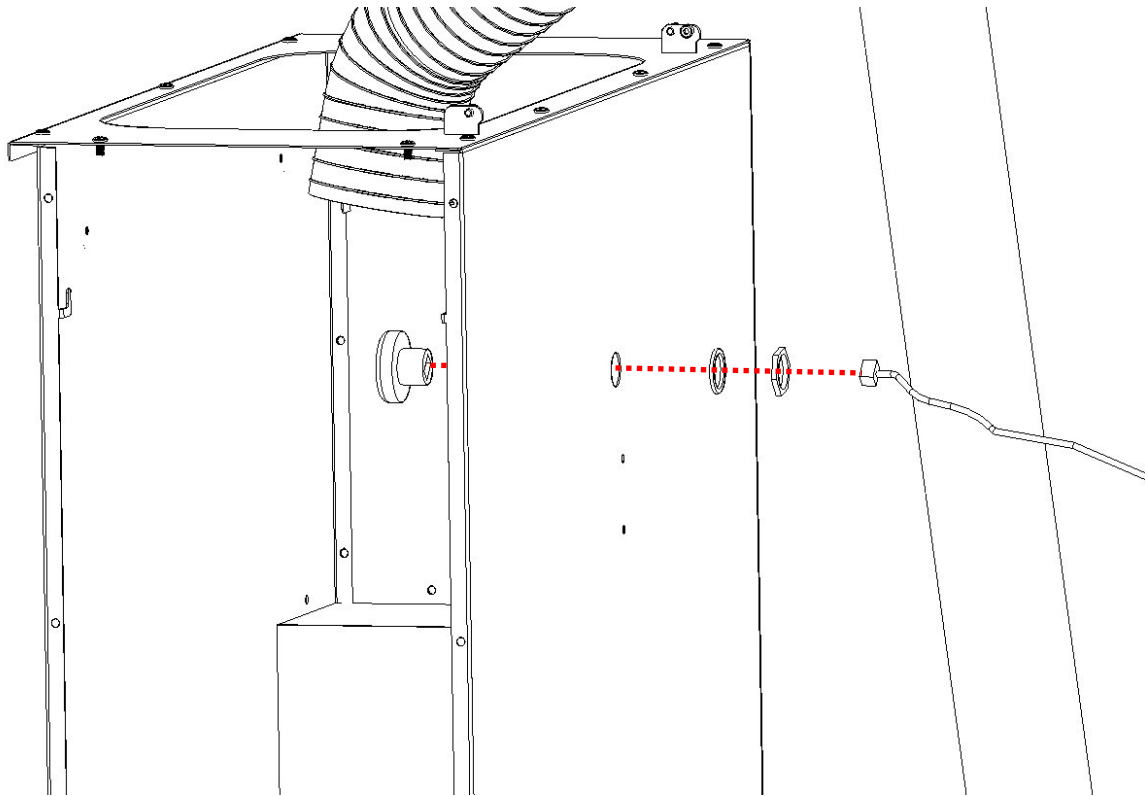

21

INTELLIGENT TANK FOR ALL

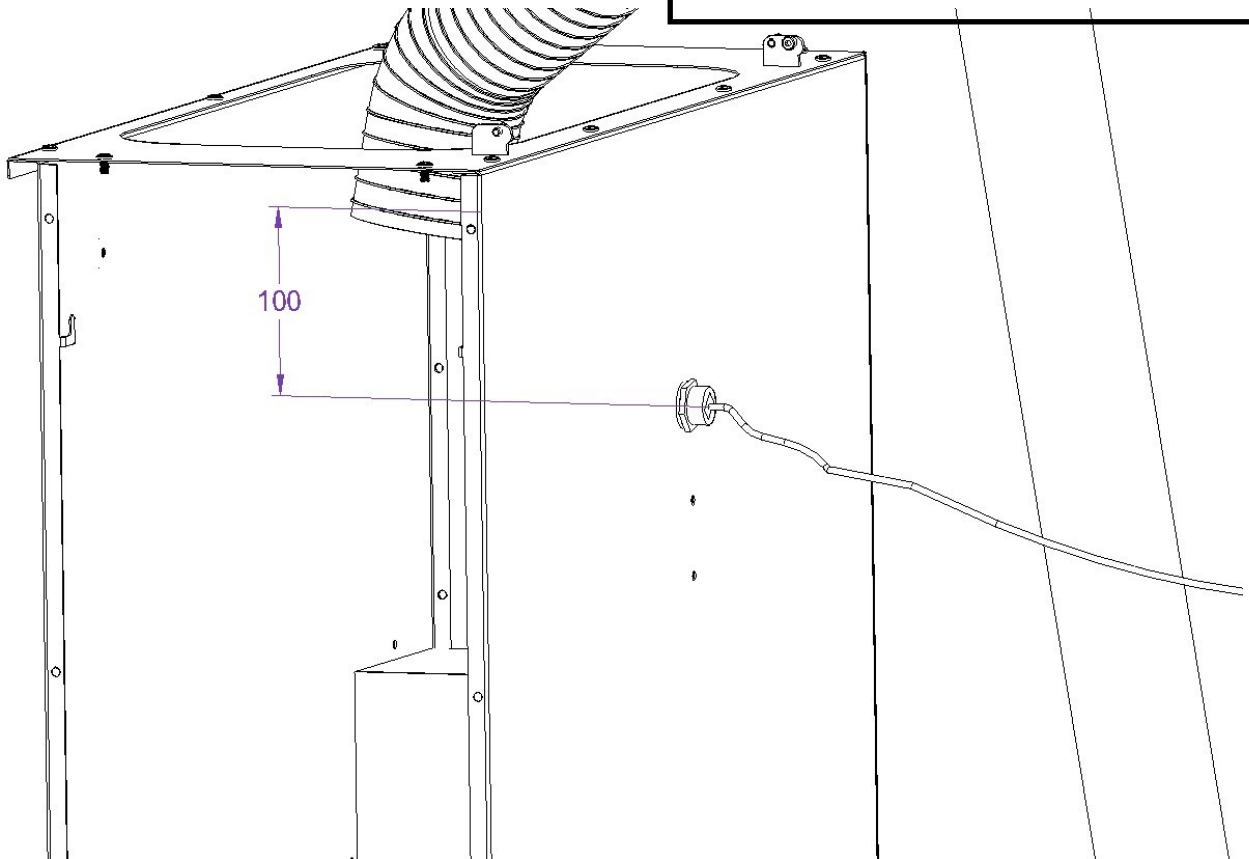

22

INTELLIGENT TANK FOR ALL

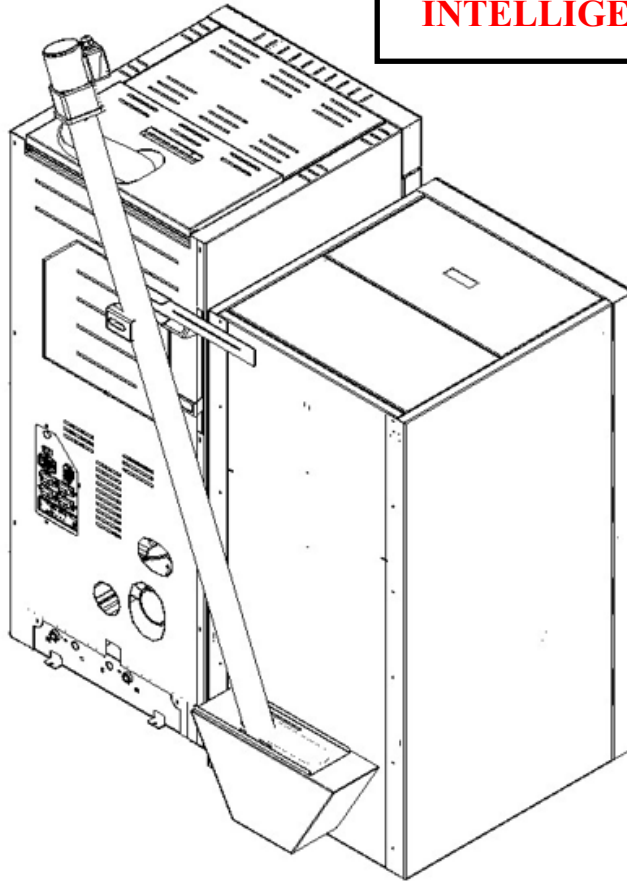

23

INTELLIGENT TANK FOR ALL

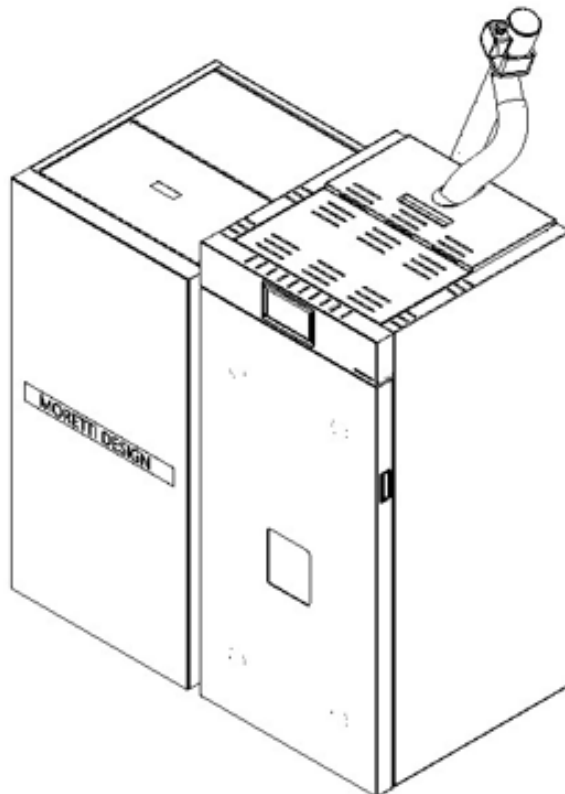

24

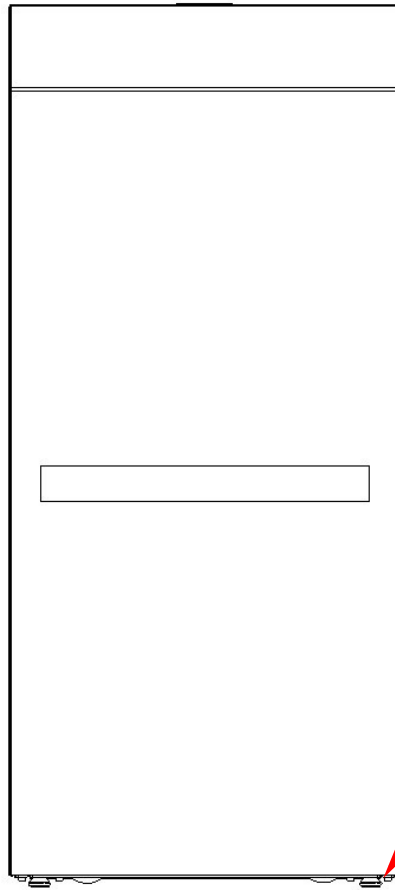

X4

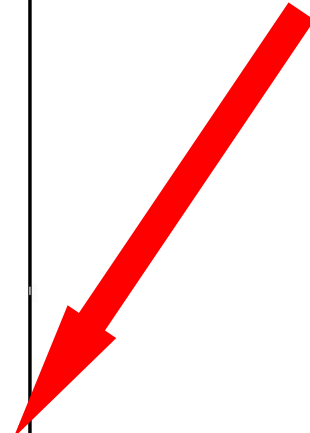
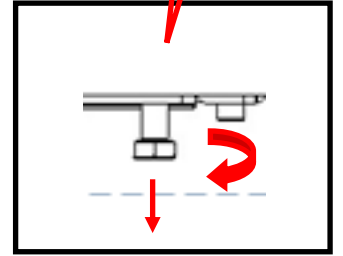

25

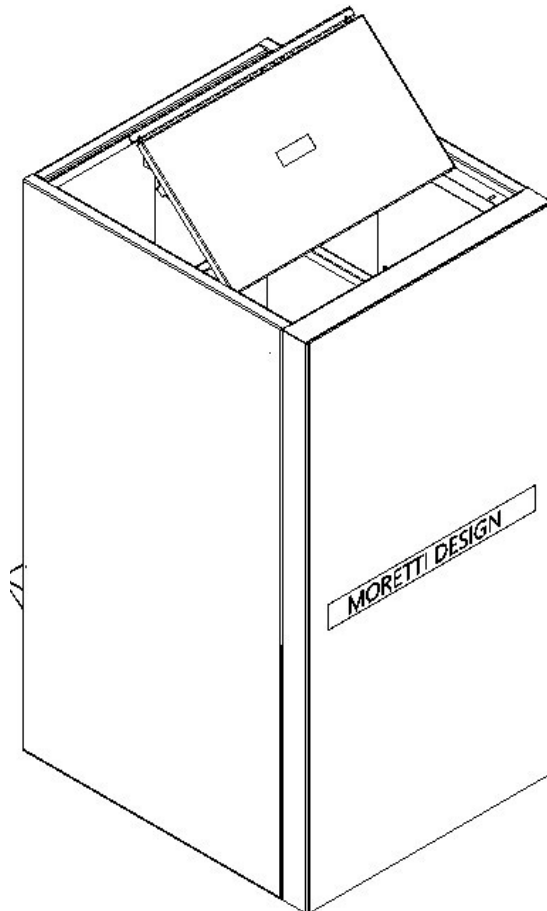

26

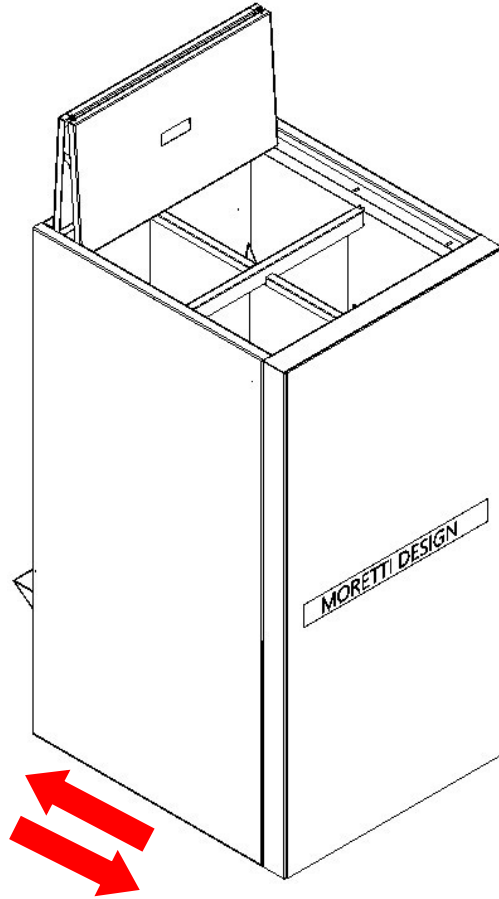

27

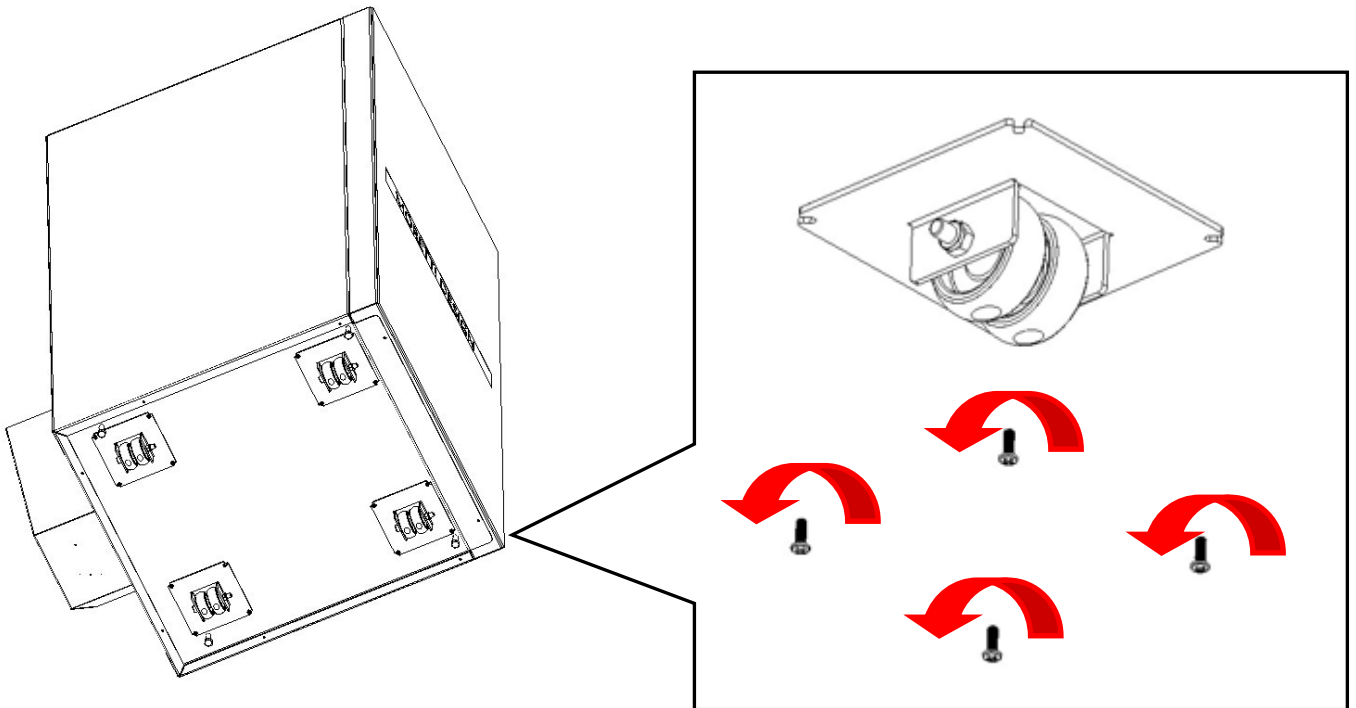

28

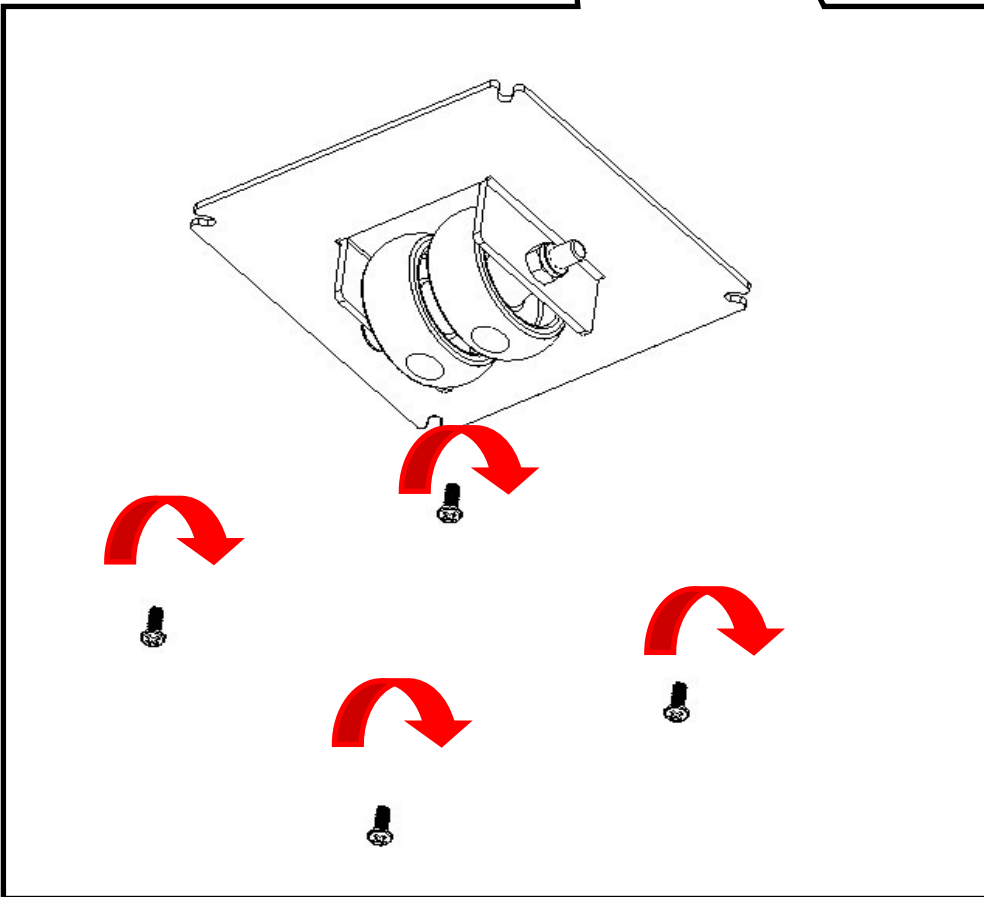
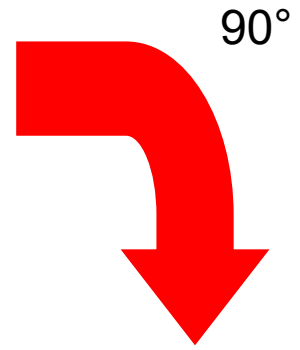
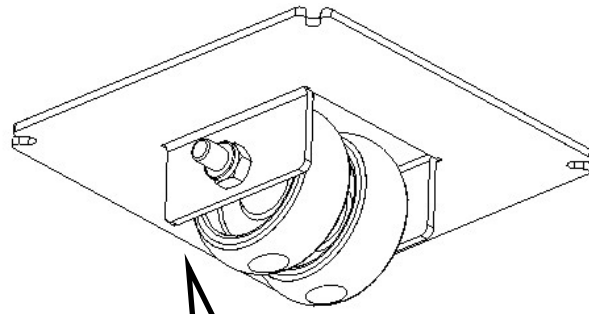

29

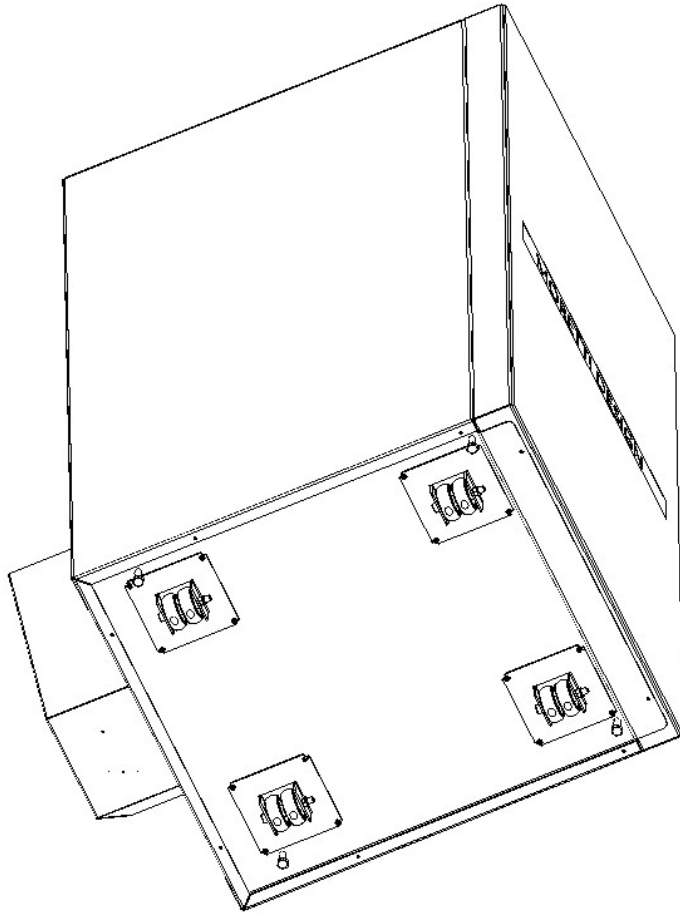

30

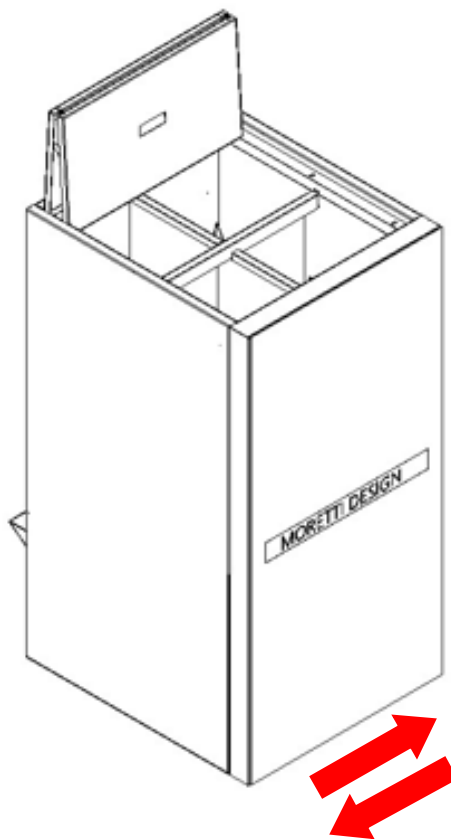

TECNICA FOR HOME & TECNICA GLASS

PSYSS0400003

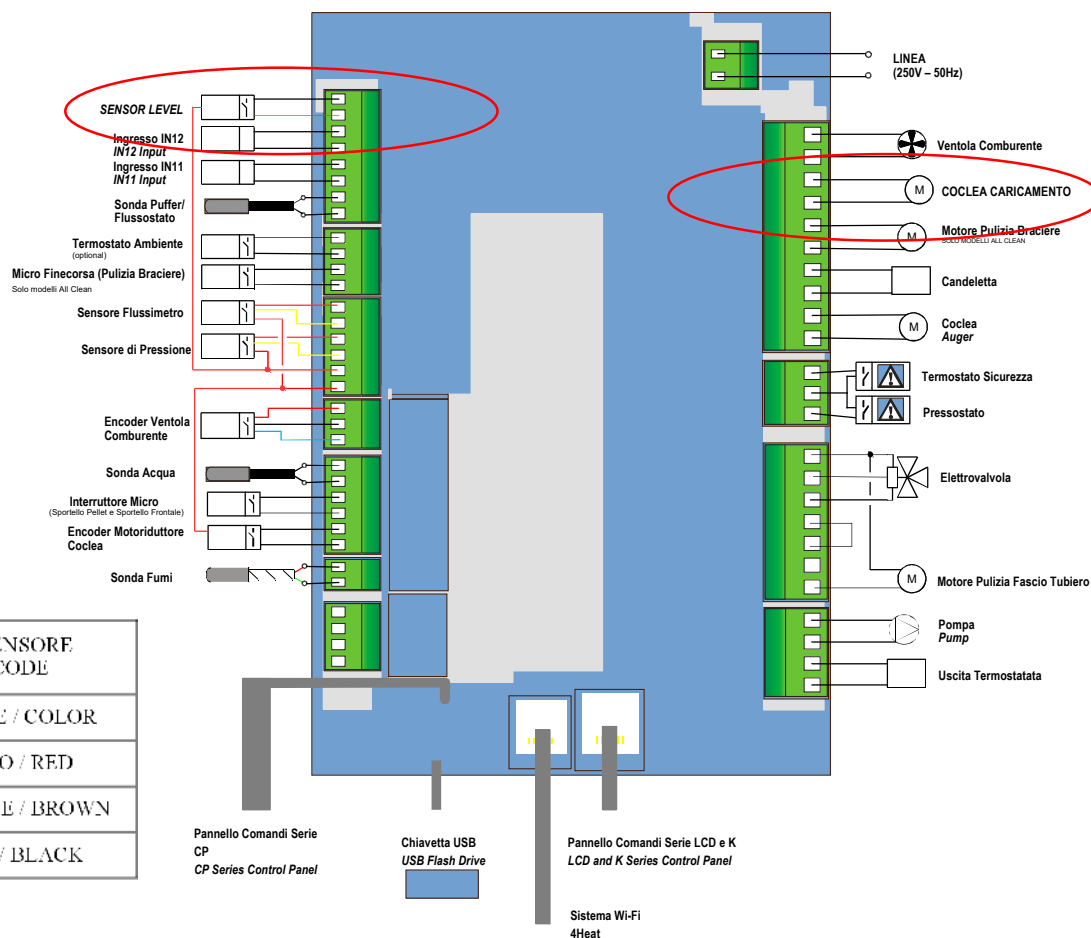

CODICE COLORE SENSORE SENSOR COLOR CODE	
TERMINAL	COLORE / COLOR
43	ROSSO / RED
58	MARRONE / BROWN
59	NERO / BLACK

PARAMETRI PARAMÈTRES PARAMETERS		TECNICA FOR HOME
P44: Configurazione Uscita V2 P44: Configuration Sortie V2 P44: Configuration of V2 output	nr	2
P84: Configurazione Ingresso IN13 P84: Configuration d'Entrée IN13 P84: IN13 input configuration	nr	6
T23: Ritardo attivazione Motore Caricamento Pellet T23: Retard d'activation du Moteur de Chargement des granulés T23: Pellet Loading Engine activation delay	min	120
T24: Durata segnalazione mancanza combustibile se un'uscita non è configurata come Motore caricamento Pellet o durata controllo riempimento combustibile se il Motore Caricamento pellet è presente T24: Durée l'avertissement de panne de carburant si une sortie n'est pas configuré comme moteur chargement ou durée de contrôle remplissage de carburant si le moteur de chargement de granules est présent T24: Duration of low fuel warning if an exit is not configured as a Pellet Loading Motor or Control duration of the fuel filling if the Pellet Loading Motor is present	sec	3600

MORETTIDESIGN

Moretti fire s.r.l.
ITALY
www.morettidesign.it

La Moretti fire s.r.l. non si assume alcuna responsabilità per eventuali errori di questo opuscolo e si ritiene libera di variare senza preavviso le caratteristiche dei propri prodotti.

The Moretti fire s.r.l. assumes no responsibility for any errors in this manual and the right to modify without notice features of its products.

Moretti fire s.r.l. no se responsabiliza por eventuales errores de este manual y es libre de modificar sin aviso previo las características de sus productos.

Moretti fire s.r.l. n'assume aucune responsabilité pour les erreurs éventuelles de ce document et se considère libre de modifier sans préavis les caractéristiques de ses produits.

Die Moretti fire s.r.l. übernimmt keine Verantwortung für eventuelle Fehler in dieser Broschüre, und es steht frei, ohne Ankündigung Charakteristiken ihrer Produkte zu ändern.

A Moretti fire s.r.l. não assume nenhuma responsabilidade por quaisquer erros neste folheto, e estará livre para mudar sem aviso prévio as características de seus produtos.

Moretti fire s.r.l. påtager sig intet ansvar for eventuelle fejl i denne manual og retten til at ændre uden varsel funktioner af sine produkter.

Moretti fire s.r.l. is niet verantwoordelijk voor eventuele fouten in deze brochure, en is vrij om zonder kennisgeving de eigenschappen van haar producten te wijzigen.

Spoločnosť Moretti fire s.r.l. nenesie zodpovednosť za žiadne chyby v tejto užívateľskej príručke a zároveň môže bez predchádzajúceho upozornenia meniť vlastnosti svojich produktov.

Společnost Moretti fire s.r.l. nenesi odpovědnost za žádné chyby v této uživatelské příručce a zároveň může bez předchozího upozornění měnit vlastnosti svých produktů.

Moretti fire s.r.l. nie ponosi żadnej odpowiedzialności za ewentualne błędy w niniejszej broszurze i nie krępuj się zmienić bez powiadomienia cechy swoich produktów.

Moretti fire s.r.l. nu își asumă nici o responsabilitate pentru orice erori în această broșură și rămâne liber de a modifica fără preaviz caracteristicile produselor sale.